

DANMARKS IDRÆTS-FORBUND
Olympisk komite

Idrætten og det aktiverende byrum

Idrættens rum og rammer – idrætspolitik for fremtiden – 25. februar 2009



Dagsorden

- Lidt om byudviklingen
- DIF's motiver for at arbejde med byudvikling
- Manual for aktiverende arkitektur
- De gode eksempler



Lidt om byudviklingen



- Sociale, fysiske og mentale barrierer for den fysiske tilgængelighed blandt byboere.
- Med baggrund i danskernes idrætsdeltagelse kan idrætsrummet ikke kun forstås som haller eller stadion
- Breder forståelse af hvad en idrætsfacilitet er = byrum, bygninger og aktivitetsområder.

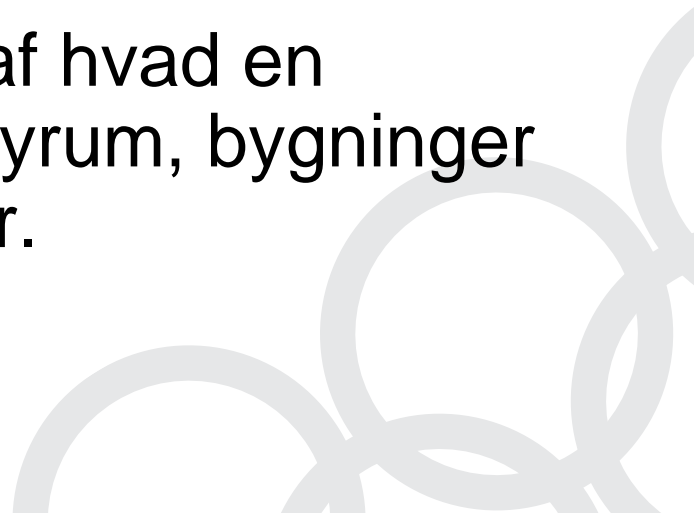



Idrætten skal integreres i nye sammenhænge



- i andre anlæg til andre formål
- skabe plads til nye idrætsgrene
- åbne for fleksibel tilrettelæggelse af brugstider
- styrke nærhedsprincipperne
- forbedre udnyttelsen af tomme arealer

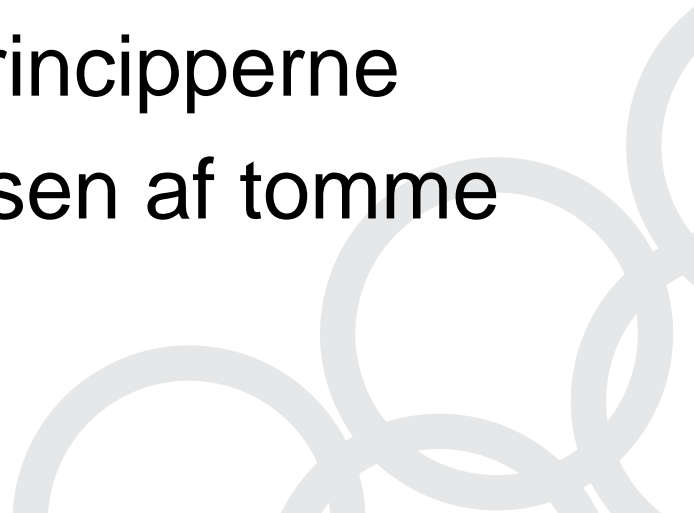



DIF's overordnede målsætninger



1. At jo flere borgere DIF kan få gjort fysisk aktive jo større sandsynlighed er der for, at disse borgere også bliver medlem af en idrætsforening under DIF.
2. At kommuner i forbindelse med byfornyelse eller byudviklingsinitiativer skal redegøre for borgernes muligheder for at få adgang til idræt, motion og fysisk aktivitet.



DIF's motiver for at arbejde med byudvikling

- flere danskere skal være aktive
- frafaldet af unge
- utidssvarende idrætsfaciliteter i storbyerne
- sætte fokus på nye og moderne idrætsaktiviteter



Manualen "Aktiverende Arkitektur"

- DIF introducerer et konkret planlægningsværktøj som kan styrke kommunernes arbejde med byplanlægning og fysisk aktivitet.
- DIF arbejder med helt ny målgruppe – arkitekter og byplanlæggere

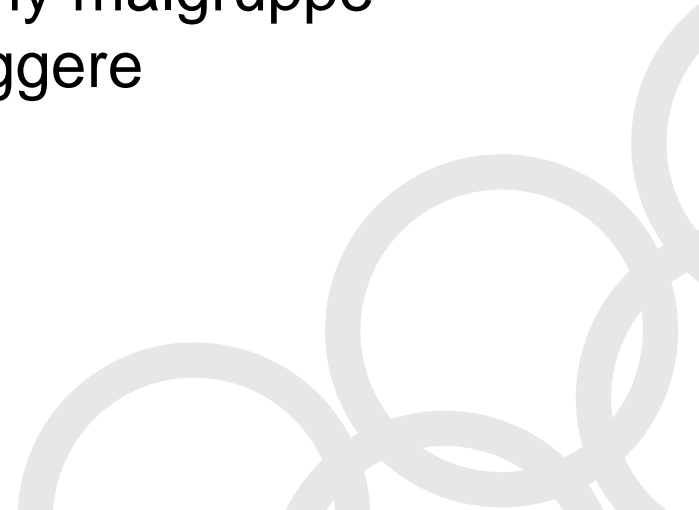



Manual for "Aktiverende Arkitektur" ser på arenaer for fysisk aktivitet



- Hverdagens aktivitetsområder
- Uformelle aktivitetsområder
- Formelle aktivitetsområder





Hverdagens aktivitetsområder

- Friarealer i boligområder
- Friarealer i erhversområder
- Facaden
- Pladsen "small"
- Pladsen "medium"
- Parkeringspladsen
- Forbindelser



Uformelle aktivitetsområder

- Overskudsarealer
- Post industrielle områder
- Skolegården
- Parken
- Det blå rum
- Tagfladen
- Byrumsinventar



Friarealer i boligområder

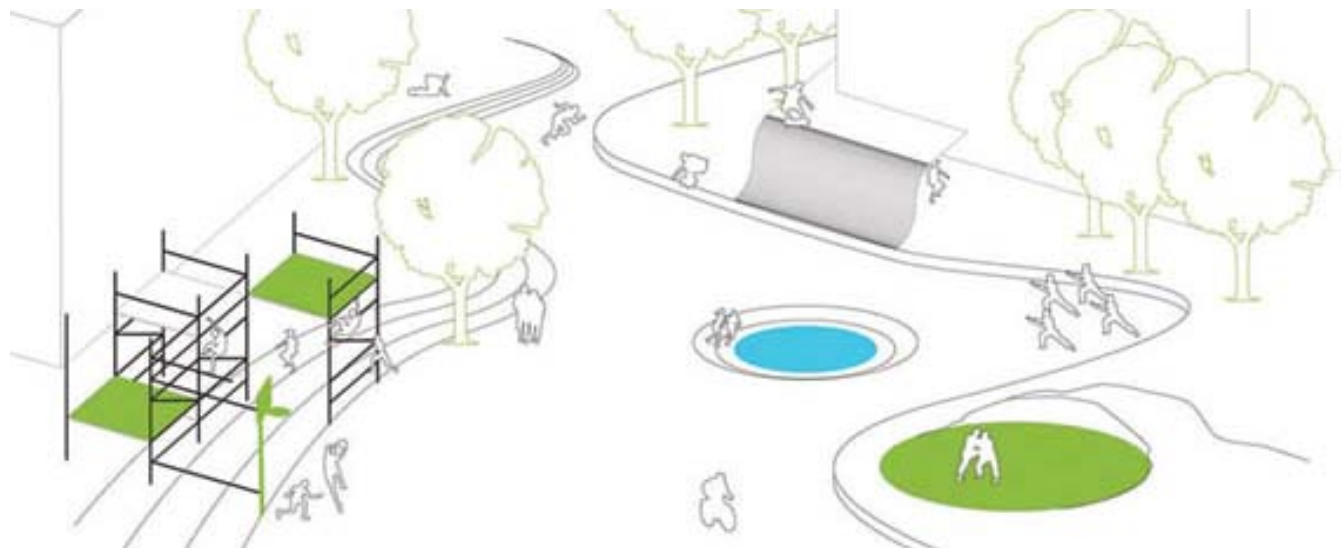

Friarealer i erhvervsområder

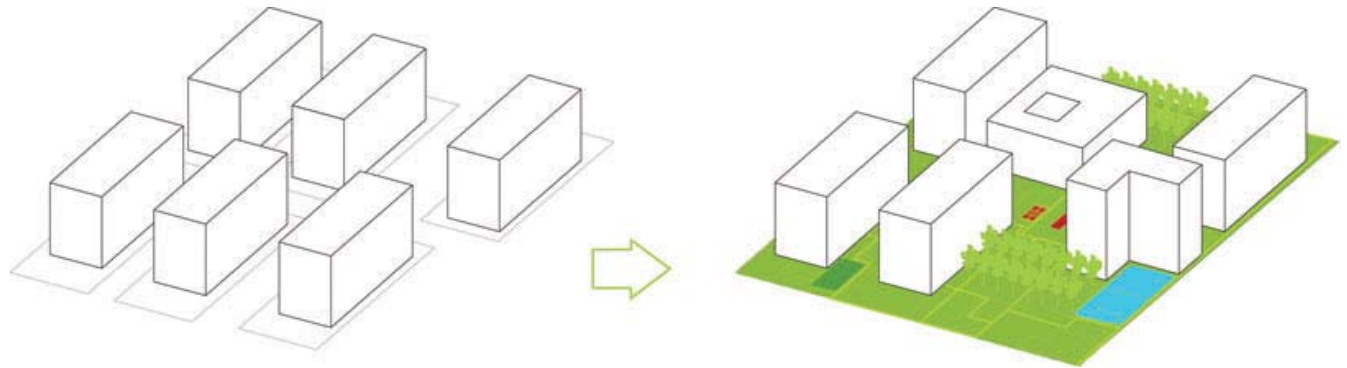

Facaden



Pladsen SMALL

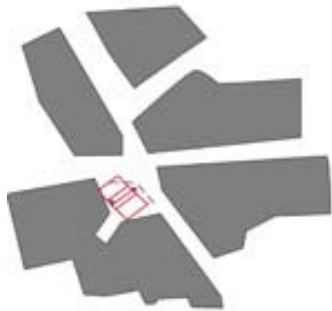
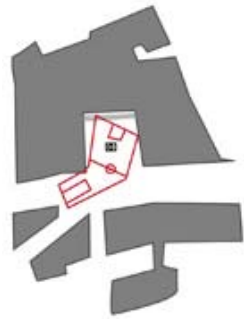

Pladsen MEDIUM



Parkeringspladsen





Forbindelser

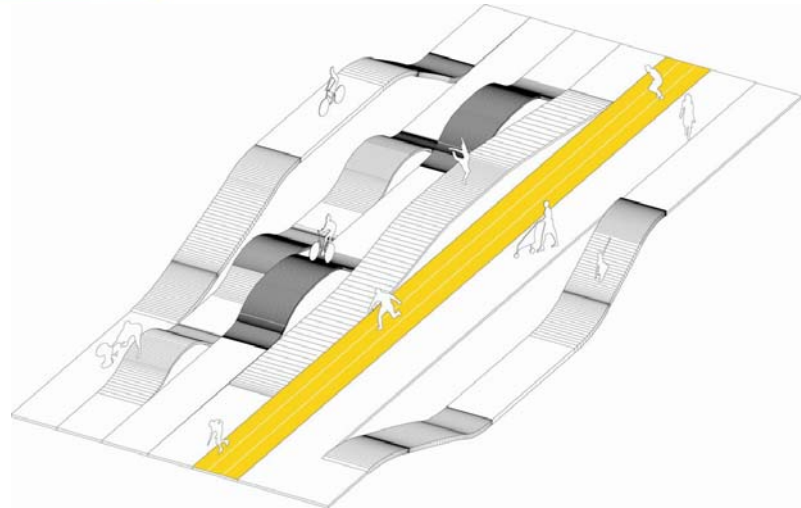
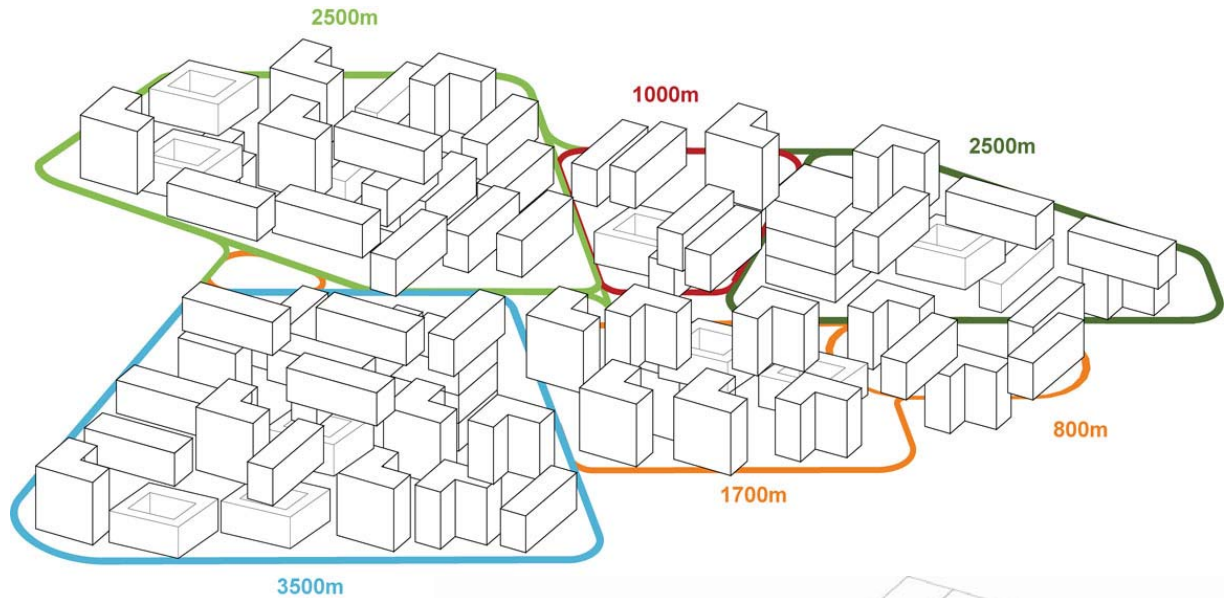

Overskudsarealer

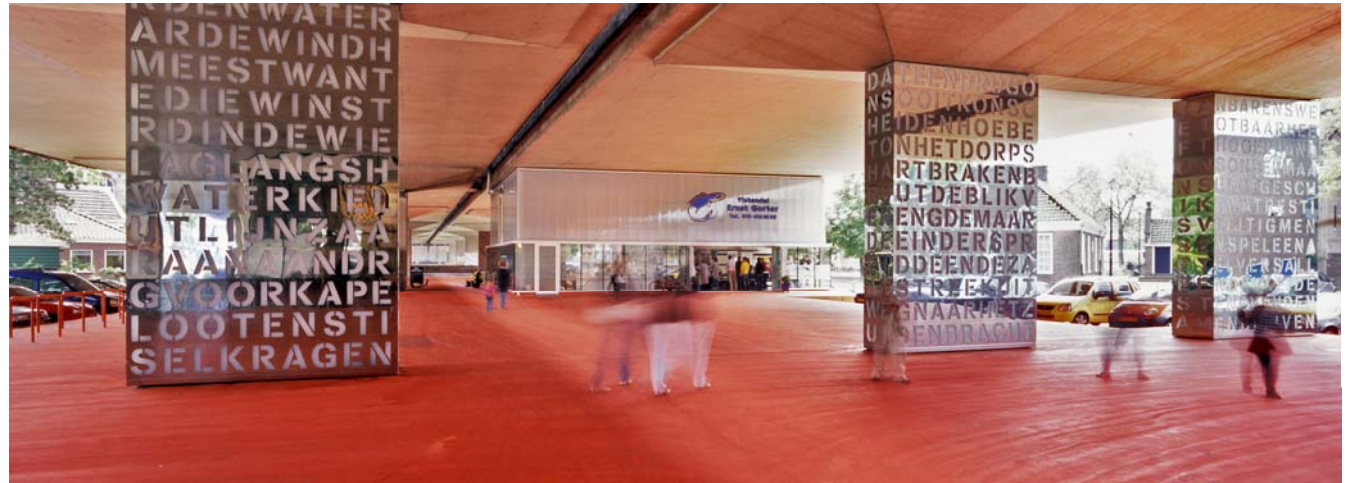

Post-industrielle områder



Skolegården



Parken



Det blå rum

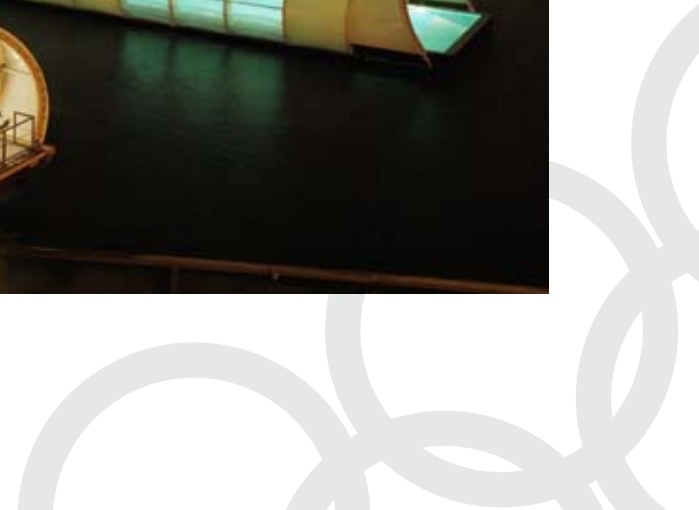

Tagfladen

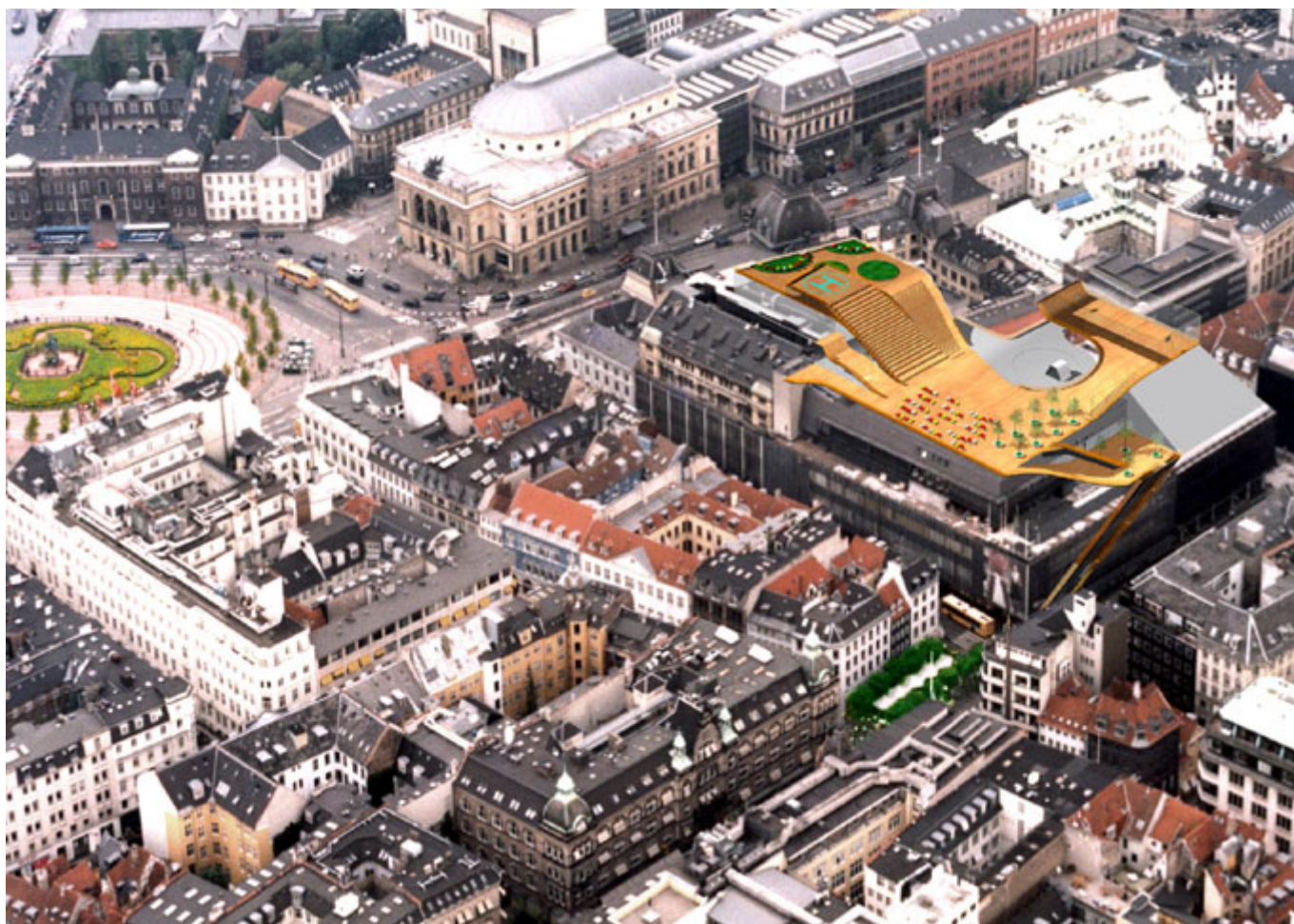

Byrumsinventar

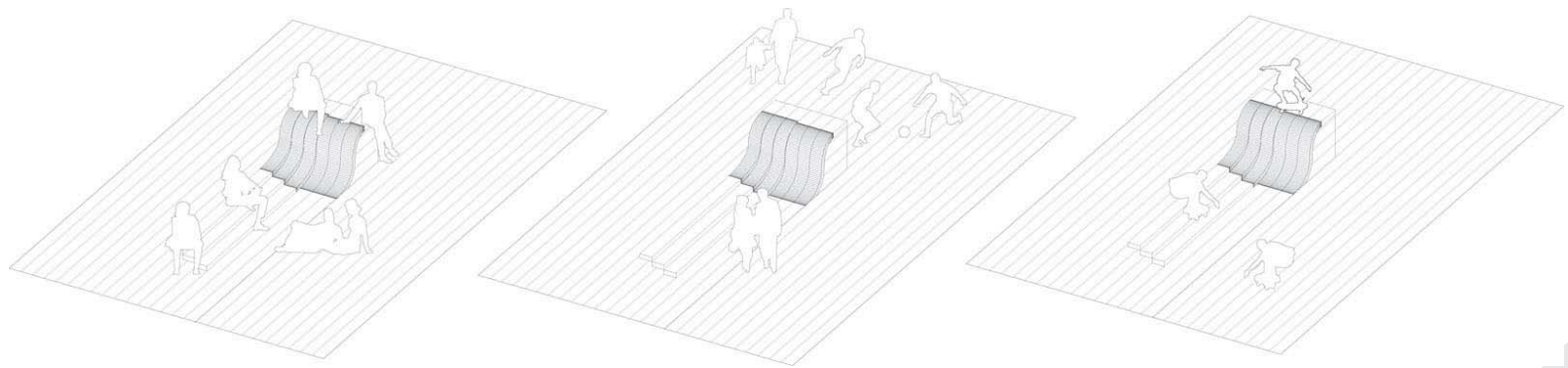

De formelle aktivitetsområder

